



LTC12-28H

Valve-regulated lead-acid battery

DEEP CYCLE SERIES

Characteristics

Nominal voltage	12V (6 cell per unit)	
Nominal capacity at 20 hours rate/10.5V (25°C)	28Ah	
Capacity (25°C)	10 Hours rate/10.5V	26.4Ah
	1 Hours rate/9.6V	18.3Ah
Terminal type	T14/T5	
Torque	5.1±0.6N.m	
Approx. internal resistance (25°C)	10 mΩ	
Dimensions	Length	166±2mm (6.54inch)
	Width	126±2mm (4.96inch)
	Height	174±2mm (6.85inch)
	Total height	174±2mm (6.85inch)
Design Life (stand-by)	JIS at 25°C	8 years
	Eurobat at 20°C	6-9 years
Weight	8.80kg (19.40 lbs)±4%	
Nominal operating temperature	25°C±3 (77±5°F)	
Operating temperature range	Discharge	-15°C~50°C (5°F~122°F)
	Charge	-10°C~50°C (14°F~122°F)
	Storage	-20°C~50°C (-4°F~122°F)
Float charging voltage at 25°C	13.5V~13.8V	
Cyclic charging voltage at 25°C	14.5V~15.0V	
Temperature compensation	Float charge	-18 mV/°C/Block
	Cycle charge	-30 mV/°C/Block
Max. charging current (A)	8.4A	
Max. discharge current for 5 seconds	360A	
Self discharge rate (25°C)	≤3%/month	
Battery container ABS UL94-HB	V-0 optional	

Overview

LTC Power Deep Cycle Series are manufactured specifically to provide outstanding performance in deep cycling applications. The batteries are designed using enhanced alloy contents plates and active paste materials.

Dimensions & Terminal Type (mm)

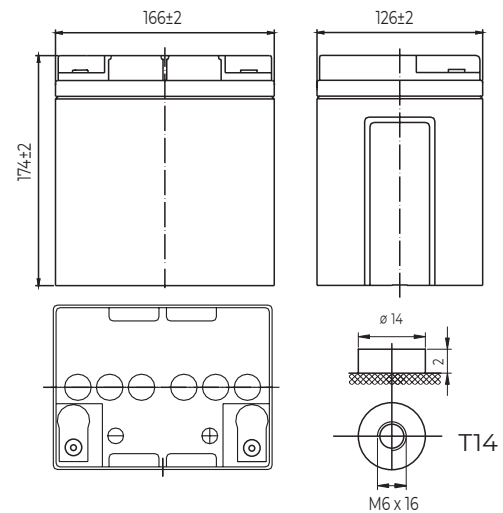

Construction

Component	Positive Plate	Negative plate	Container	Separator	Electrolyte	Safety valve	Terminal
Raw material	Lead dioxide	Lead	ABS (V-0 opt.)	AGM	Sulfuric Acid	Rubber	Copper

Constant current discharge characteristics at 25°C

(Ampere/battery)

F.V/Time	5min	10min	15min	30min	60min	2hr	3hr	4hr	5hr	10hr	20hr
9.60V	107	67.8	52.9	29.8	18.3	10.1	7.01	5.80	4.93	2.68	1.44
9.90V	104	65.7	51.6	29.2	18.1	10.1	6.97	5.76	4.90	2.67	1.43
10.2V	99.5	63.0	49.7	28.3	17.6	9.98	6.92	5.72	4.87	2.65	1.42
10.5V	95.2	60.3	48.1	27.6	17.3	9.83	6.87	5.68	4.84	2.64	1.41
10.8V	89.8	56.9	45.5	26.6	16.7	9.58	6.67	5.51	4.69	2.59	1.39

Constant power discharge characteristics at 25°C

(Watts/battery)

F.V/Time	5min	10min	15min	30min	60min	2hr	3hr	4hr	5hr	10hr	20hr
9.60V	1194	764	603	342	212	119	83.3	69.1	58.9	32.1	17.2
9.90V	1158	741	589	335	209	118	82.8	68.6	58.5	32.0	17.2
10.2V	1110	711	567	325	204	117	82.2	68.2	58.1	31.9	17.1
10.5V	1062	680	548	317	200	115	81.6	67.7	57.7	31.7	17.0
10.8V	1003	642	519	305	194	112	79.2	65.7	56.0	31.0	16.6

The above characteristics represent average values and can be obtained within three charge and discharge cycles. The batteries must be fully charged before testing. The data in this document is subject to change without notice and become contractual only after written confirmation.